

Annexe C

Cycle de fonctionnement

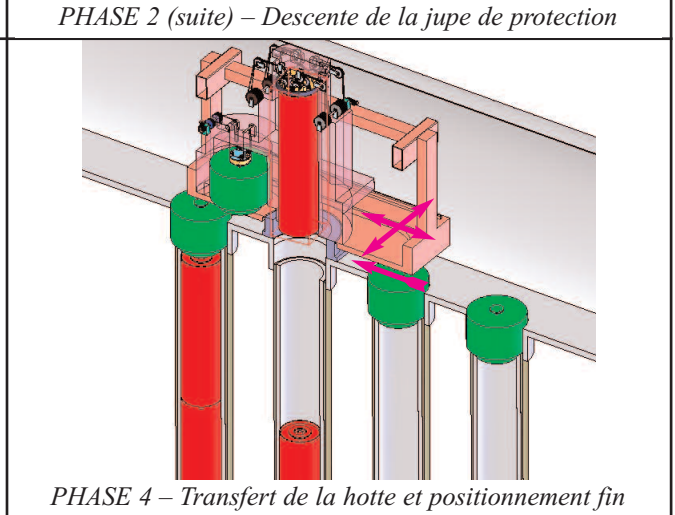

Annexe C (suite)
Cycle de fonctionnement

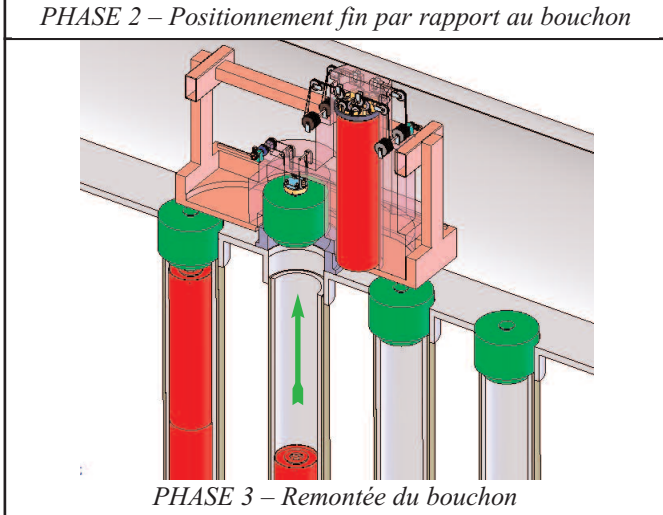
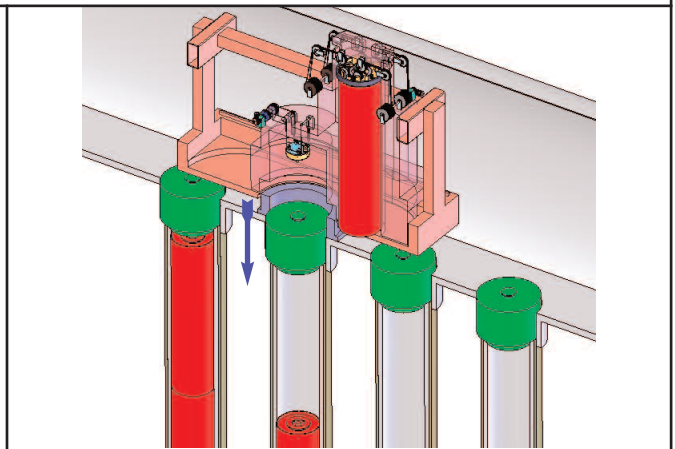
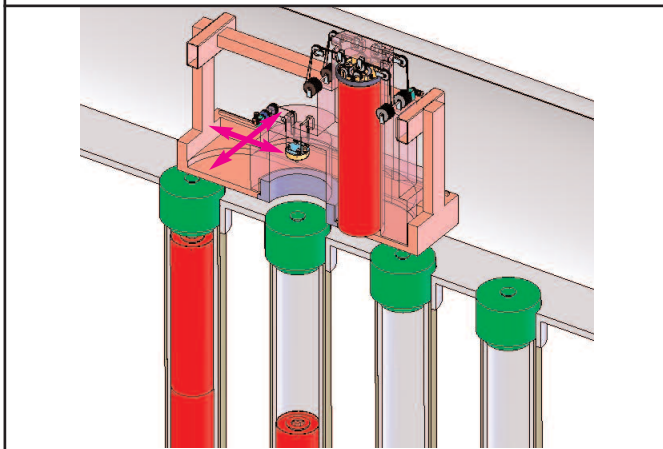
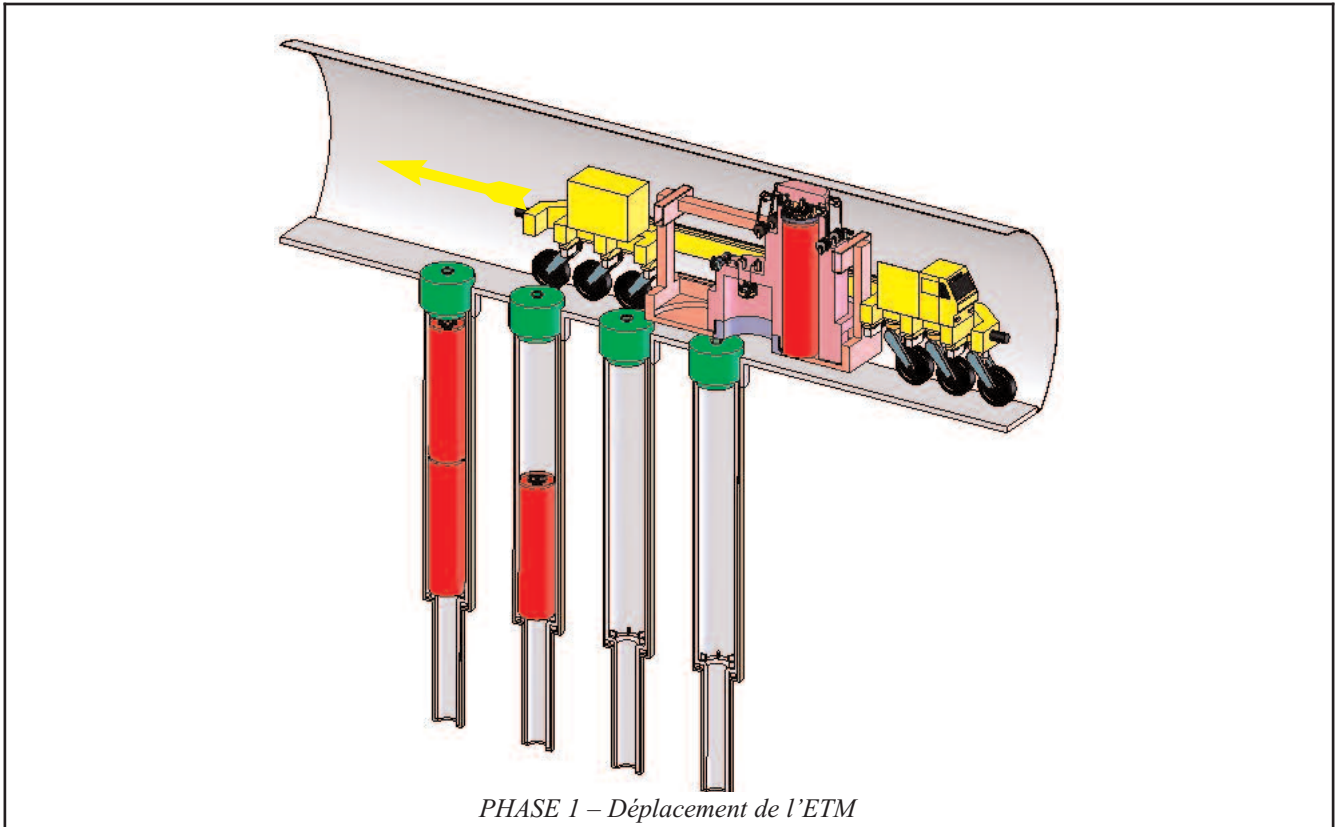
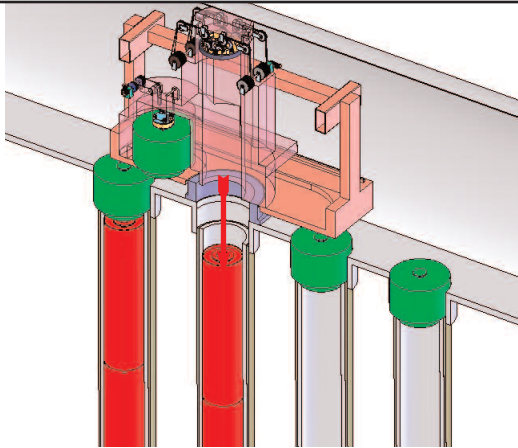

PHASE 5 – Dépose du conteneur dans le puits

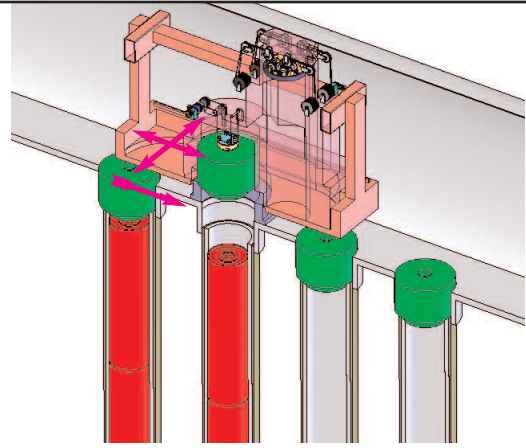

PHASE 6 – Transfert de la hotte et positionnement fin

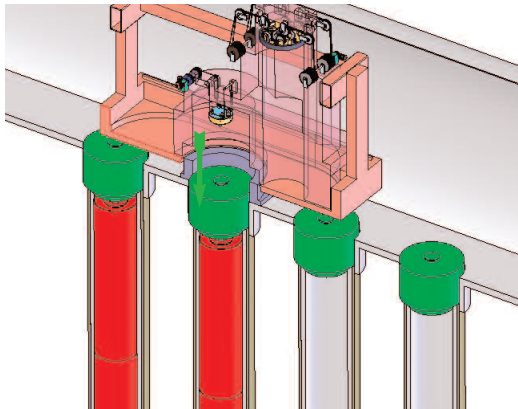

PHASE 7 – Dépose du bouchon

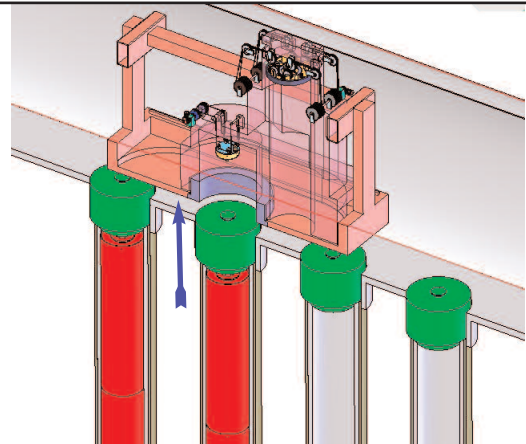

PHASE 7 (suite) – Remontée de la jupe de protection

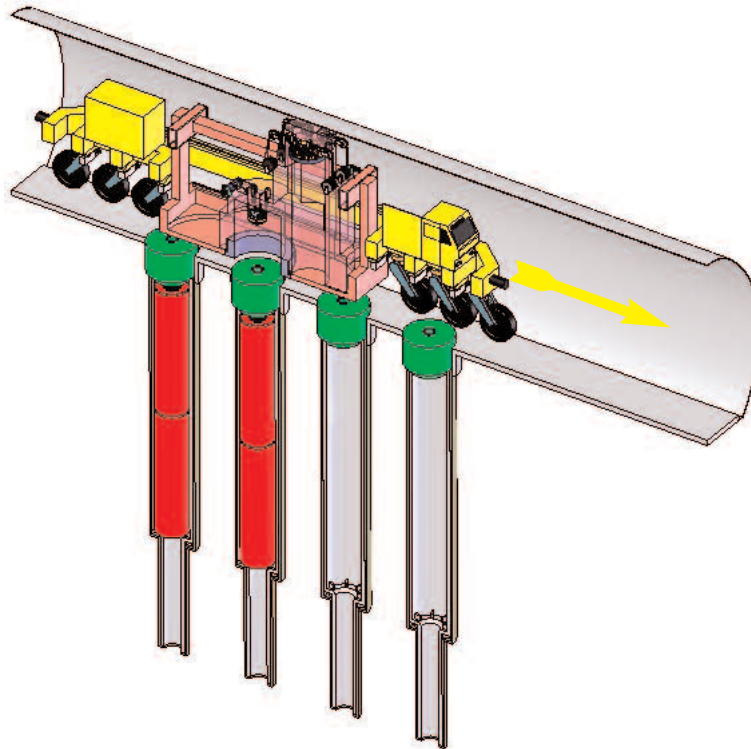

PHASE 8 – Transfert ETM