

DOSSIER REPONSES

13 DOCUMENTS

REPERE DU DOCUMENT	CONTENU	PARTIE CONCERNEE
<i>DR1</i>	<i>Etude de la fonderie</i>	<i>A</i>
<i>DR2</i>	<i>Etude de la fonderie</i>	<i>A</i>
<i>DR3</i>	<i>Etude de la fonderie</i>	<i>A</i>
<i>DR4</i>	<i>Porte pièce de la phase 20</i>	<i>B</i>
<i>DR5-1 et DR5-2</i>	<i>Silhouettes du carter principal</i>	<i>B</i>
<i>DR6</i>	<i>Contrat de phase</i>	<i>B</i>
<i>DR7</i>	<i>Modèle géométrique du pavillon</i>	<i>B</i>
<i>DR8</i>	<i>Analyse suivant la normale à A</i>	<i>B</i>
<i>DR9</i>	<i>Analyse suivant la perpendiculaire à la normale à A</i>	<i>B</i>
<i>DR10-1 et DR10-2</i>	<i>Silhouettes du carter principal</i>	<i>B</i>
<i>DR11</i>	<i>Silhouettes du rouet centrifuge</i>	<i>C</i>

Etude de fonderie

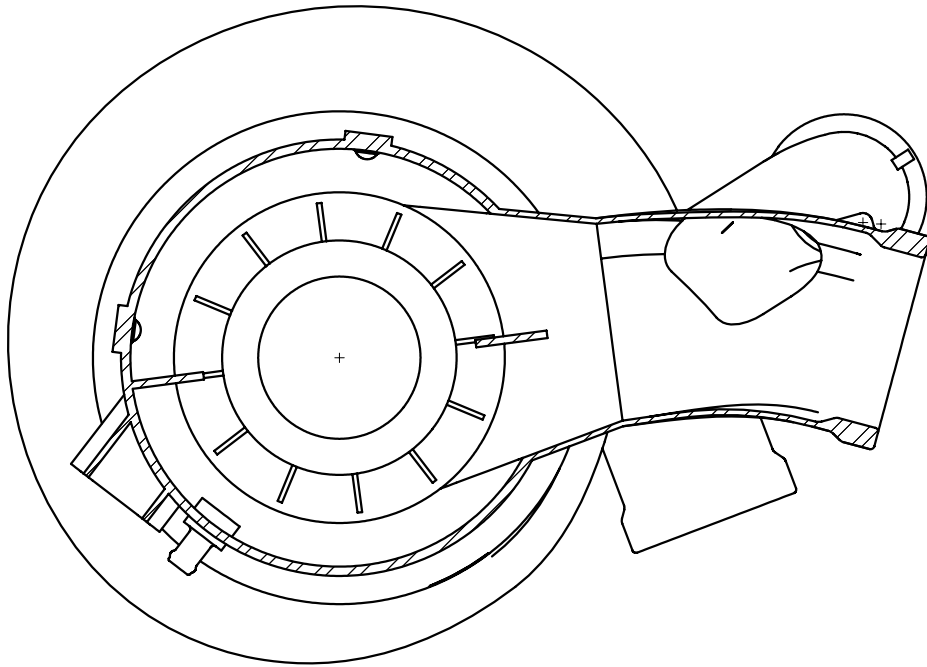
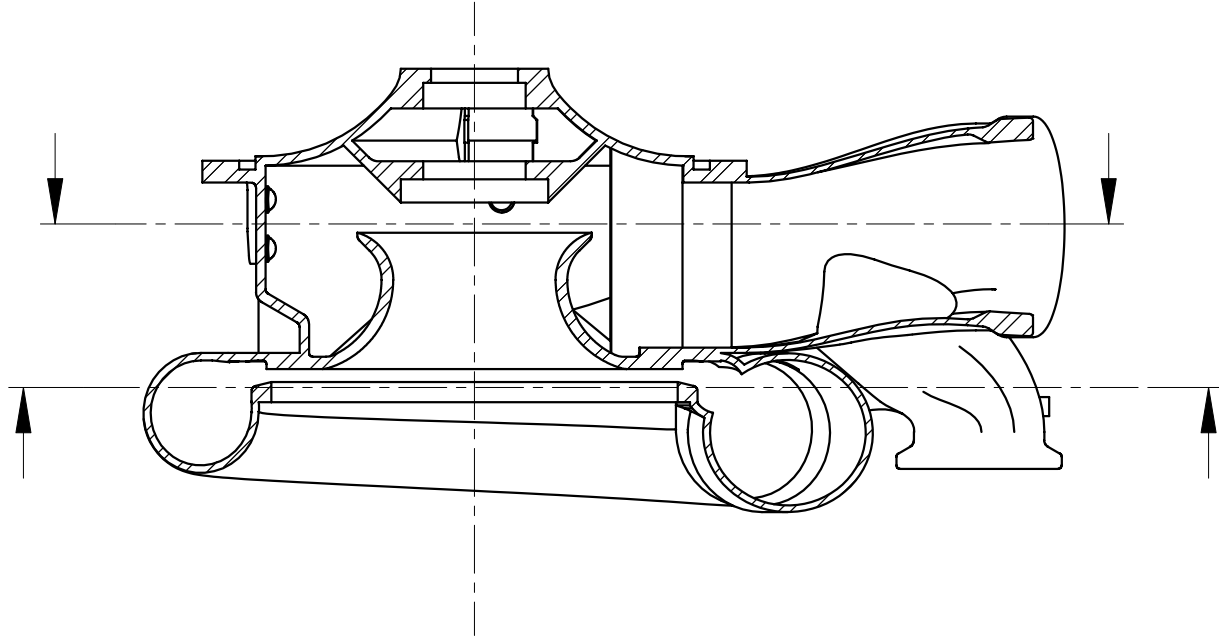
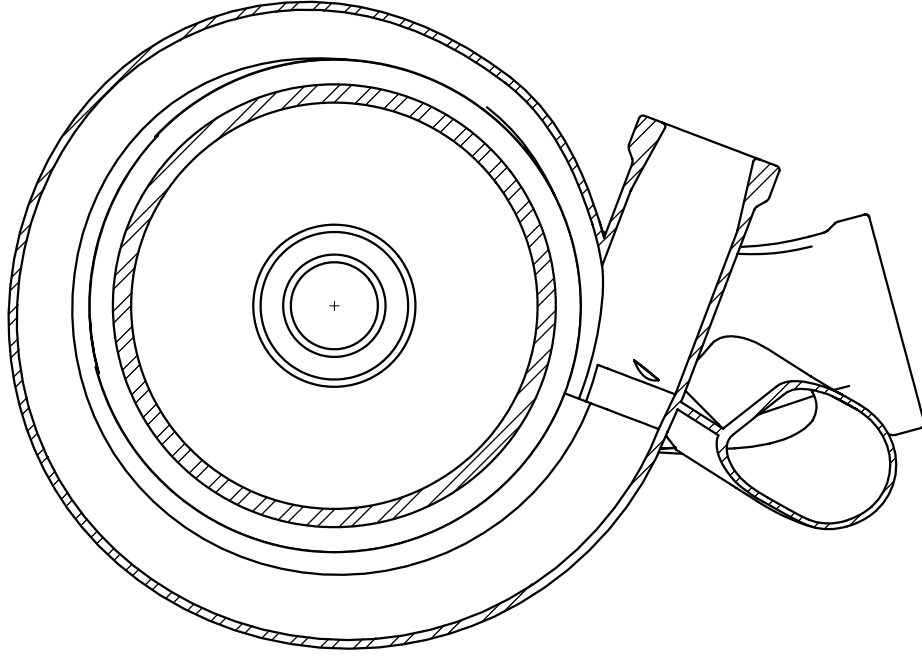

Etude de fonderie

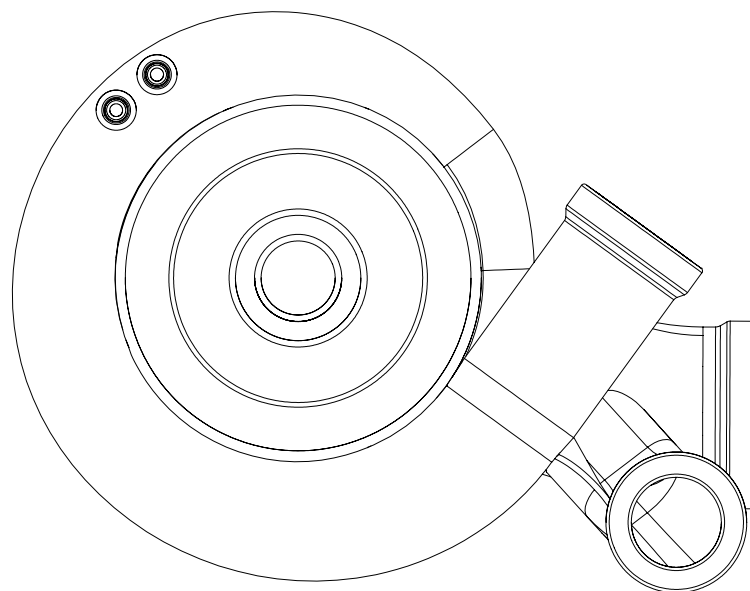

Etude de fonderie

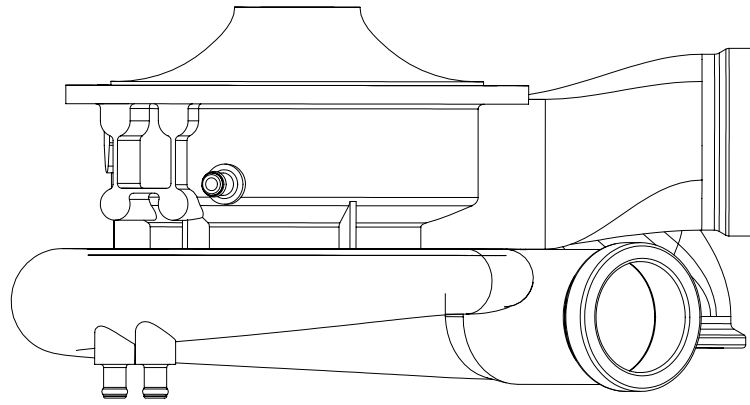
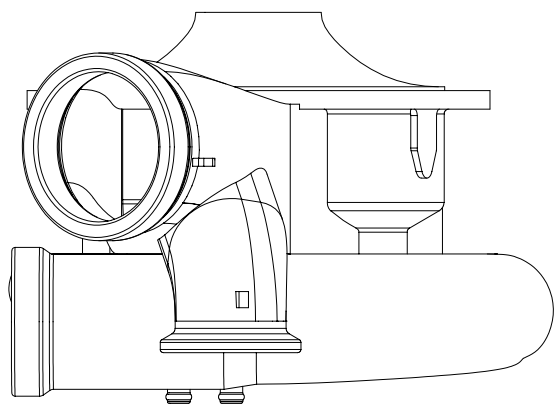

Etude de fonderie

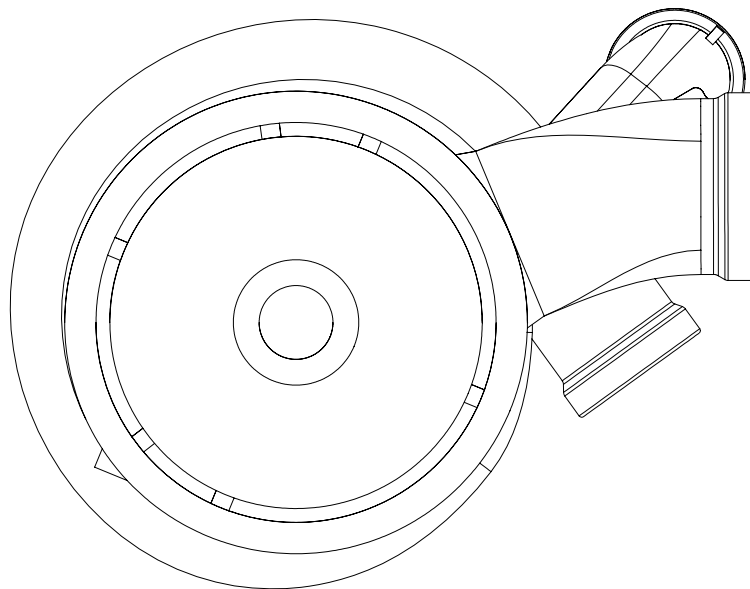

Etude de fonderie

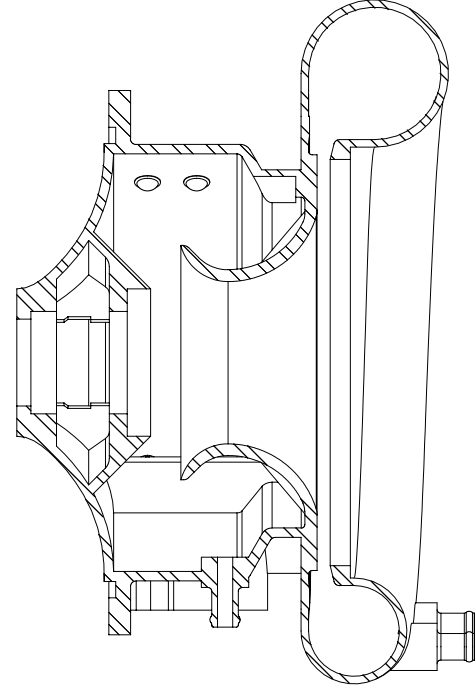
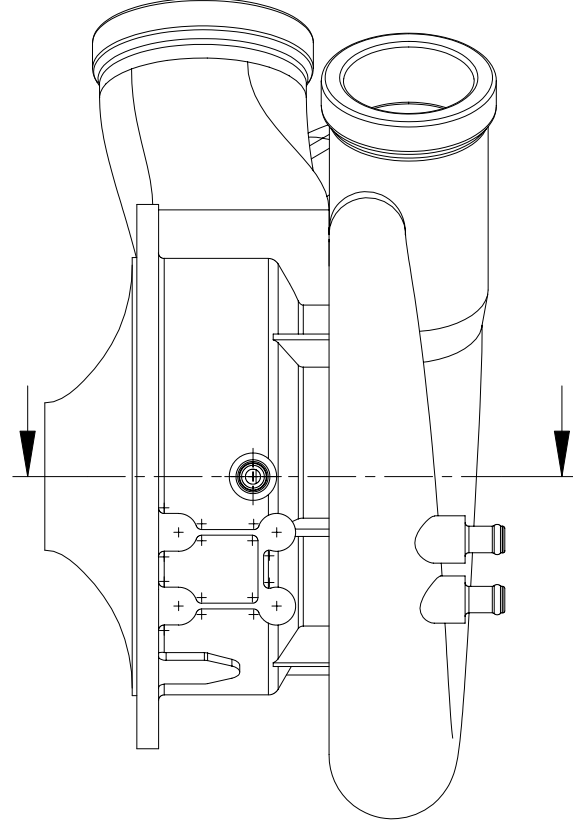
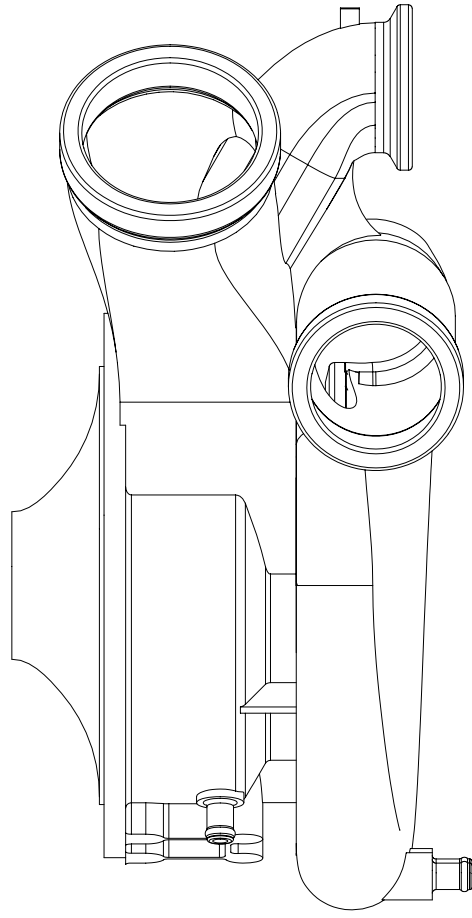
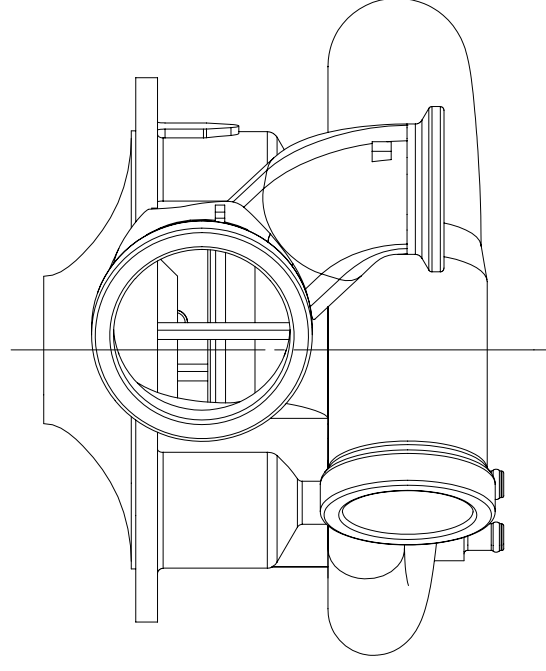

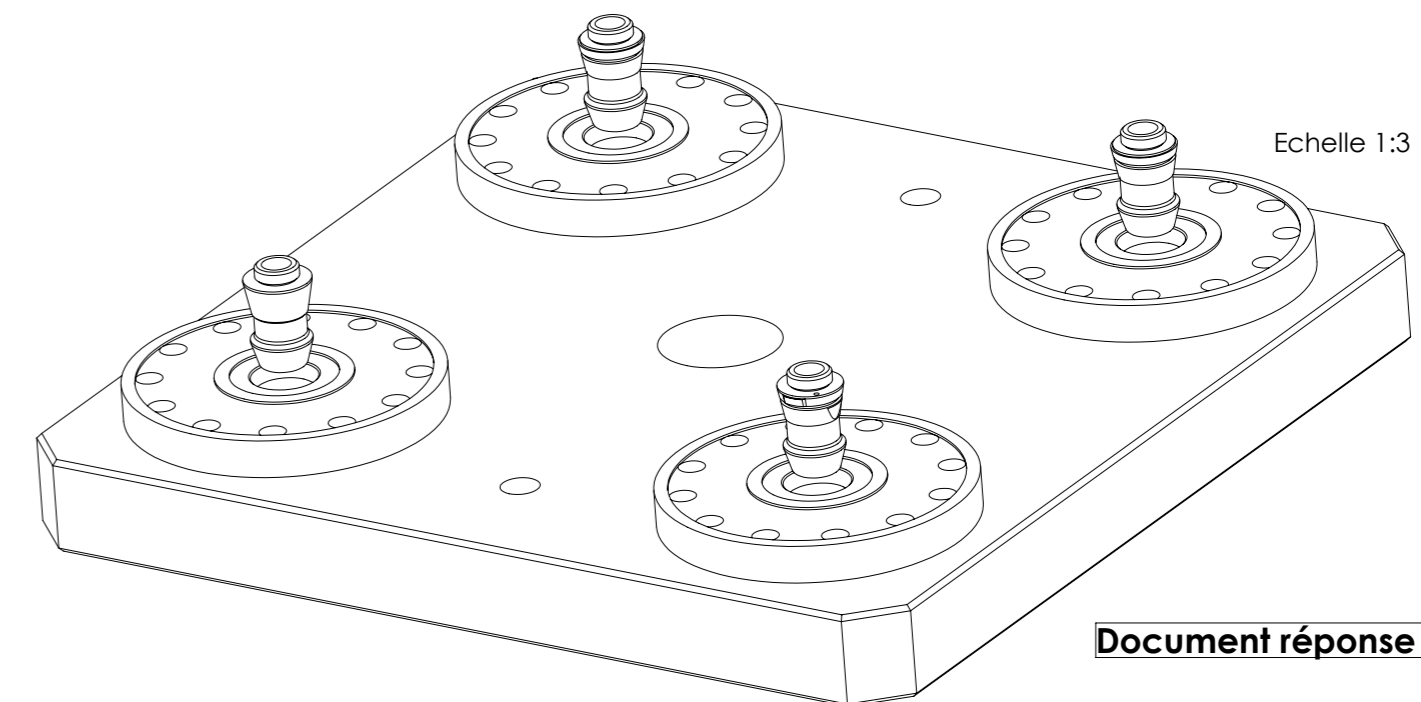
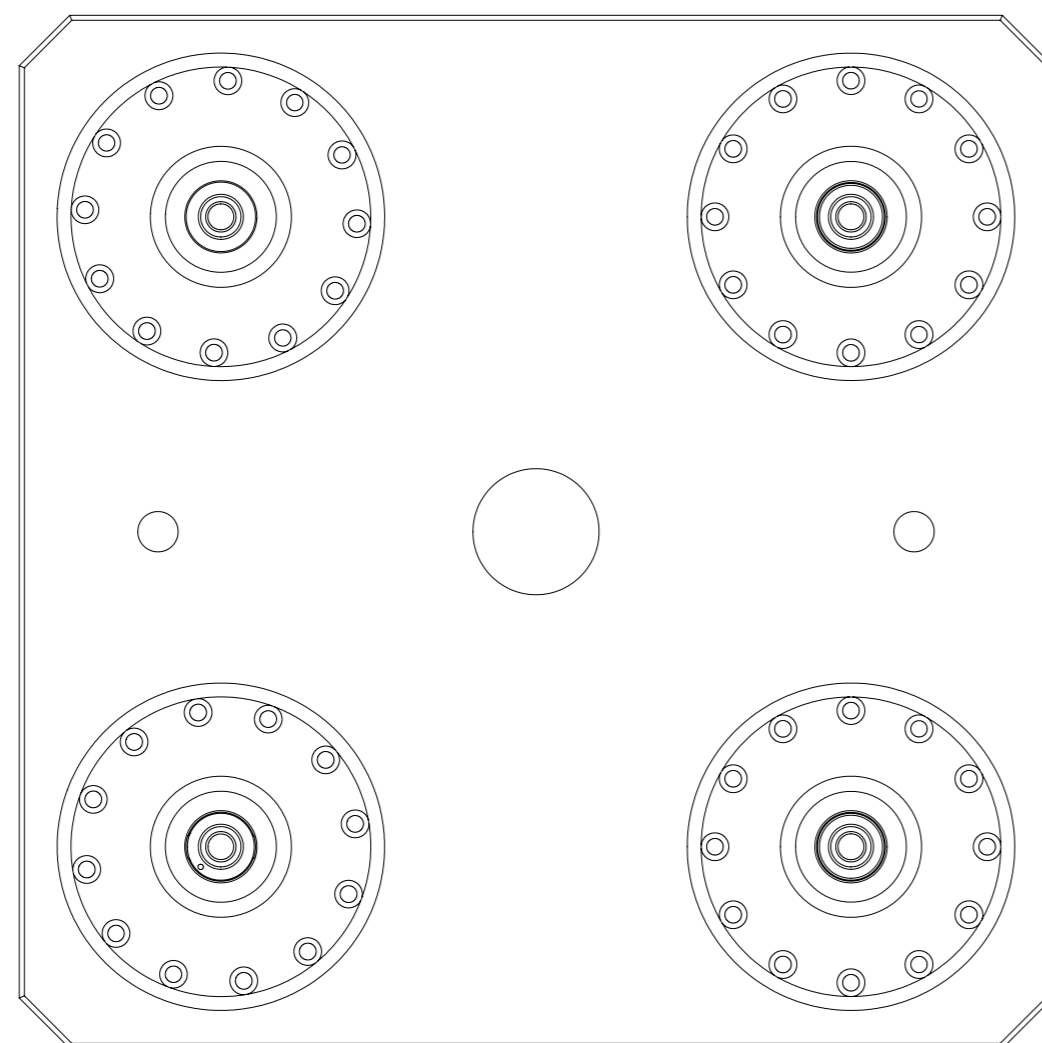
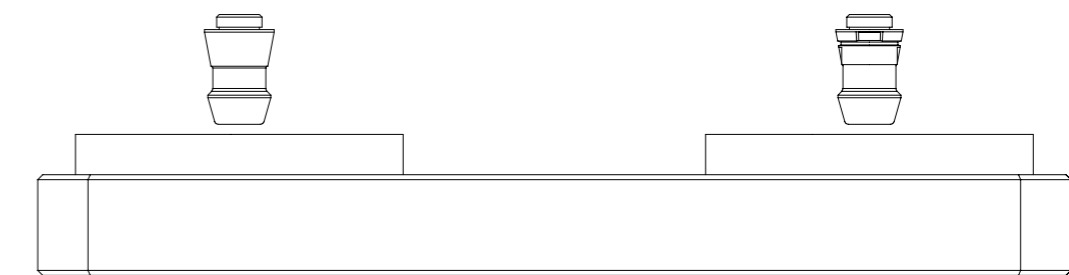
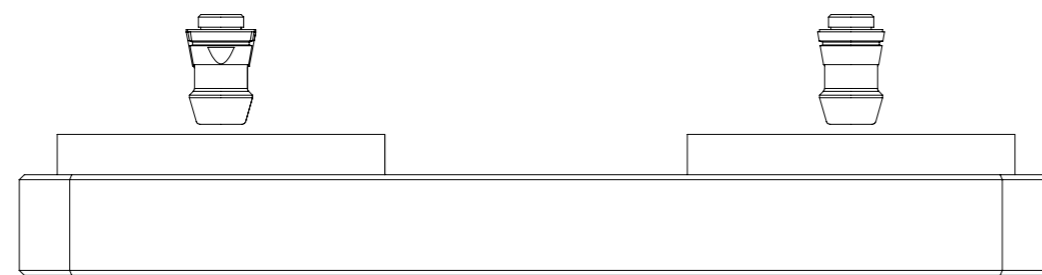

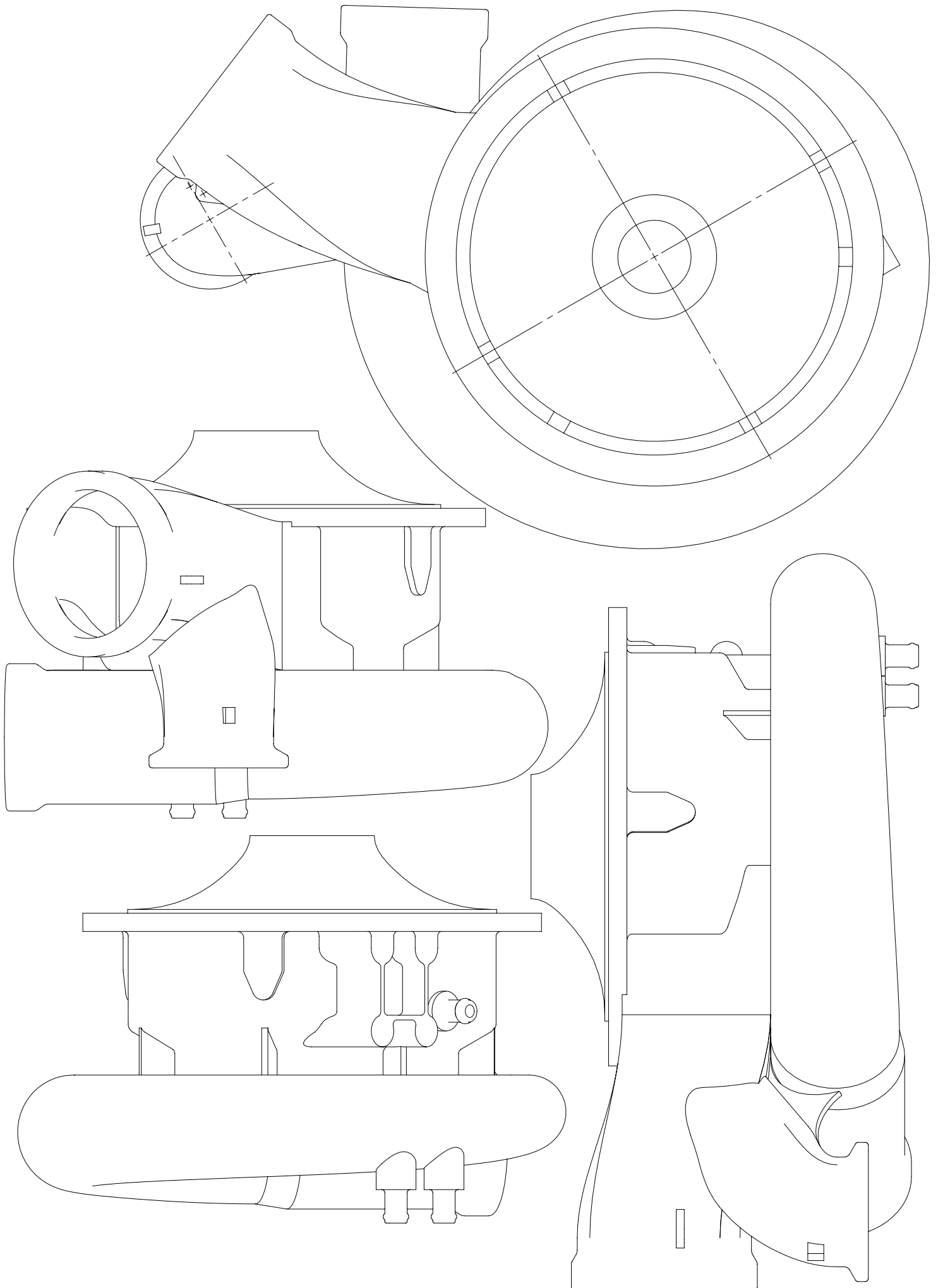

Document réponse DR 5-1

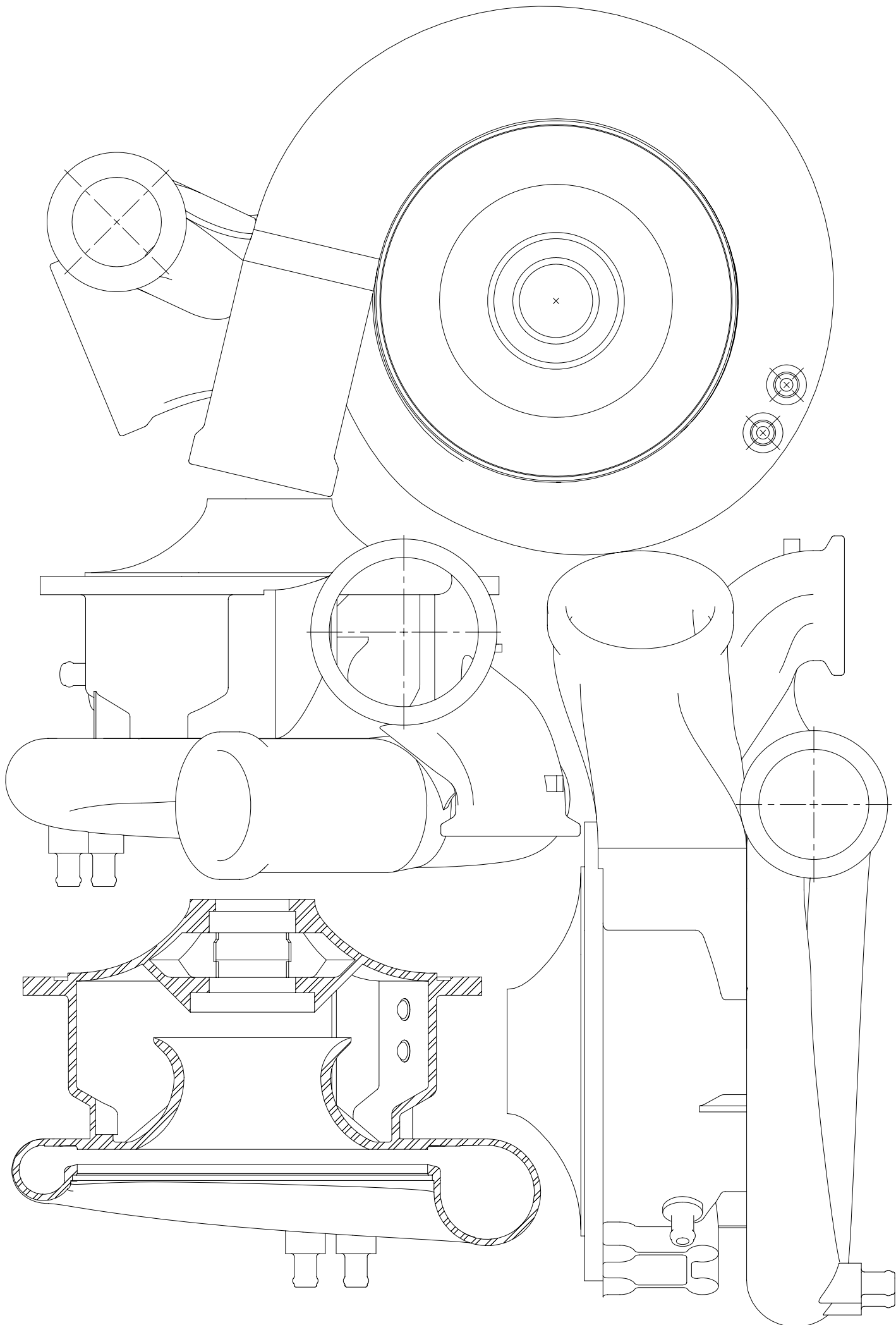

CONTRAT de la PHASE N°:

SCHEMA :

Pièce: Ensemble: Matière: Brut:
 Programme: Cadence: Temps série alloué (Ts):

DESIGNATION DE LA PHASE : Date:

MACHINE-OUTIL : Etabli par:

INSTALLATION de la PIECE
 Appui:
 Orientation - Centrage:
 Butée:
 Maintien en position:

N°op	Désignation des opérations	Désignation des outils	Vc	n	f	Vf	a _p	Tt
			m/min	tr/min	mm/dt	mm/min	mm	cmin

Modèle géométrique du pavillon

Carter principal - Turbo machine

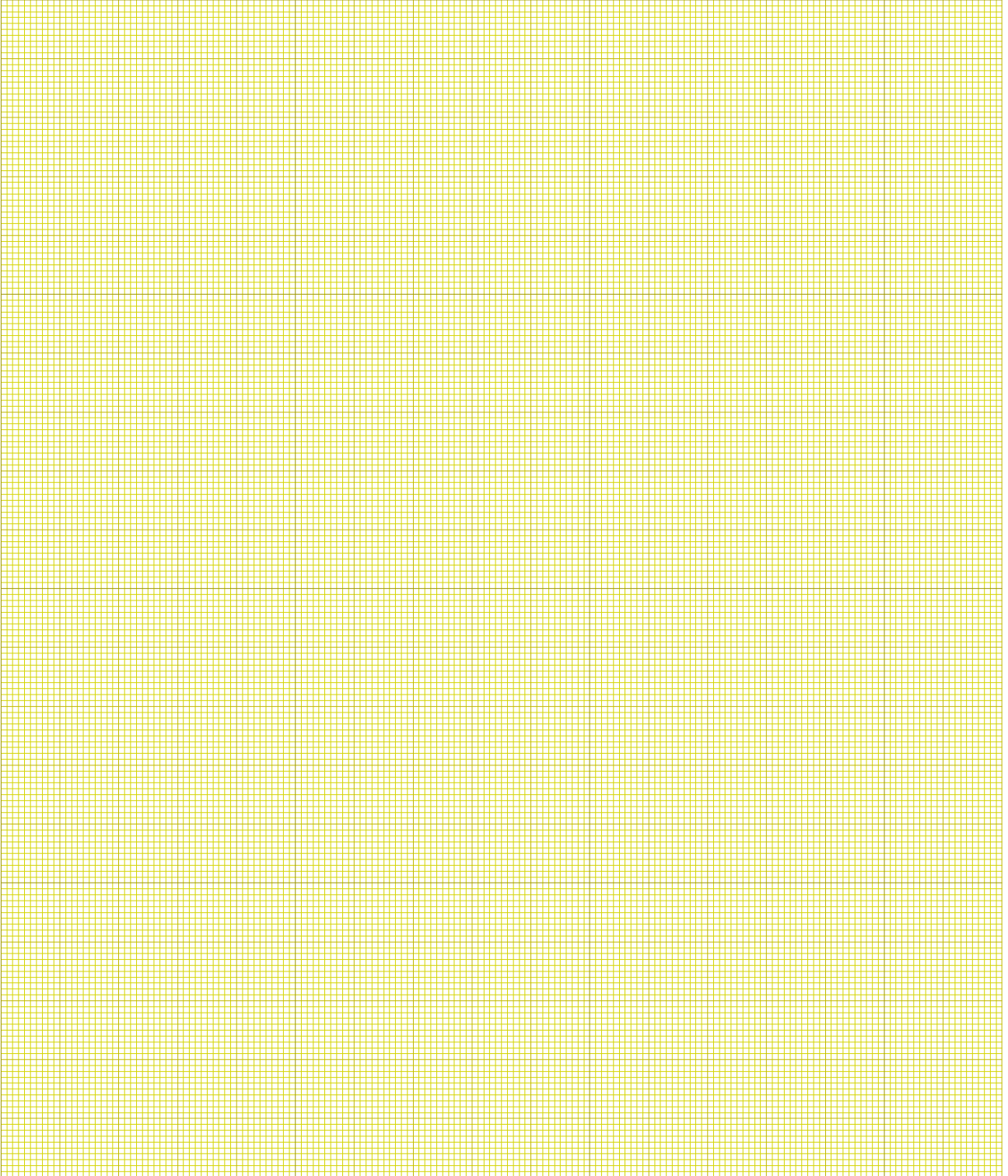

Analyse suivant la normale à la surface A

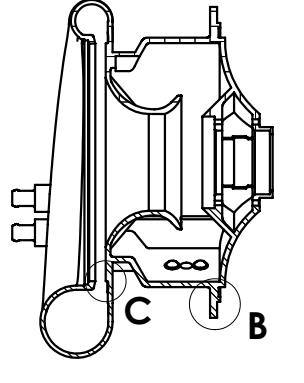
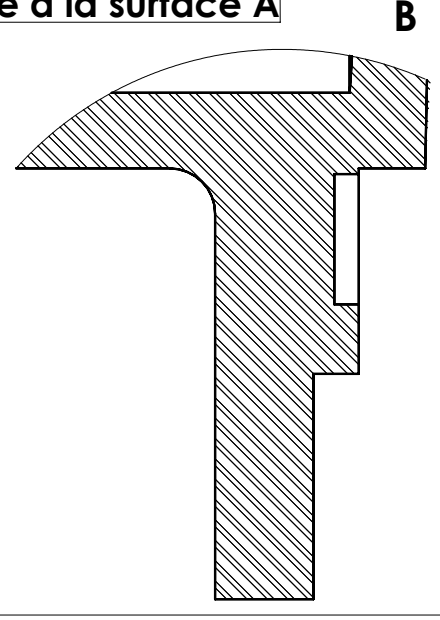
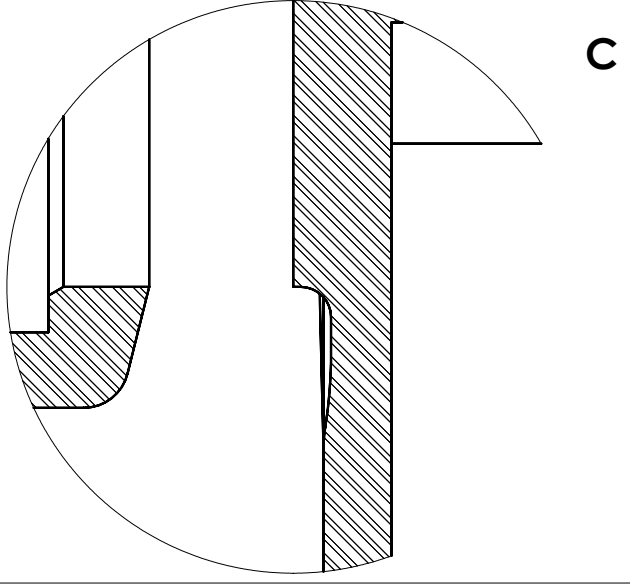

A large area of horizontal lines for writing the answer to the analysis question.

Analyse suivant la perpendiculaire à la normale à la surface A

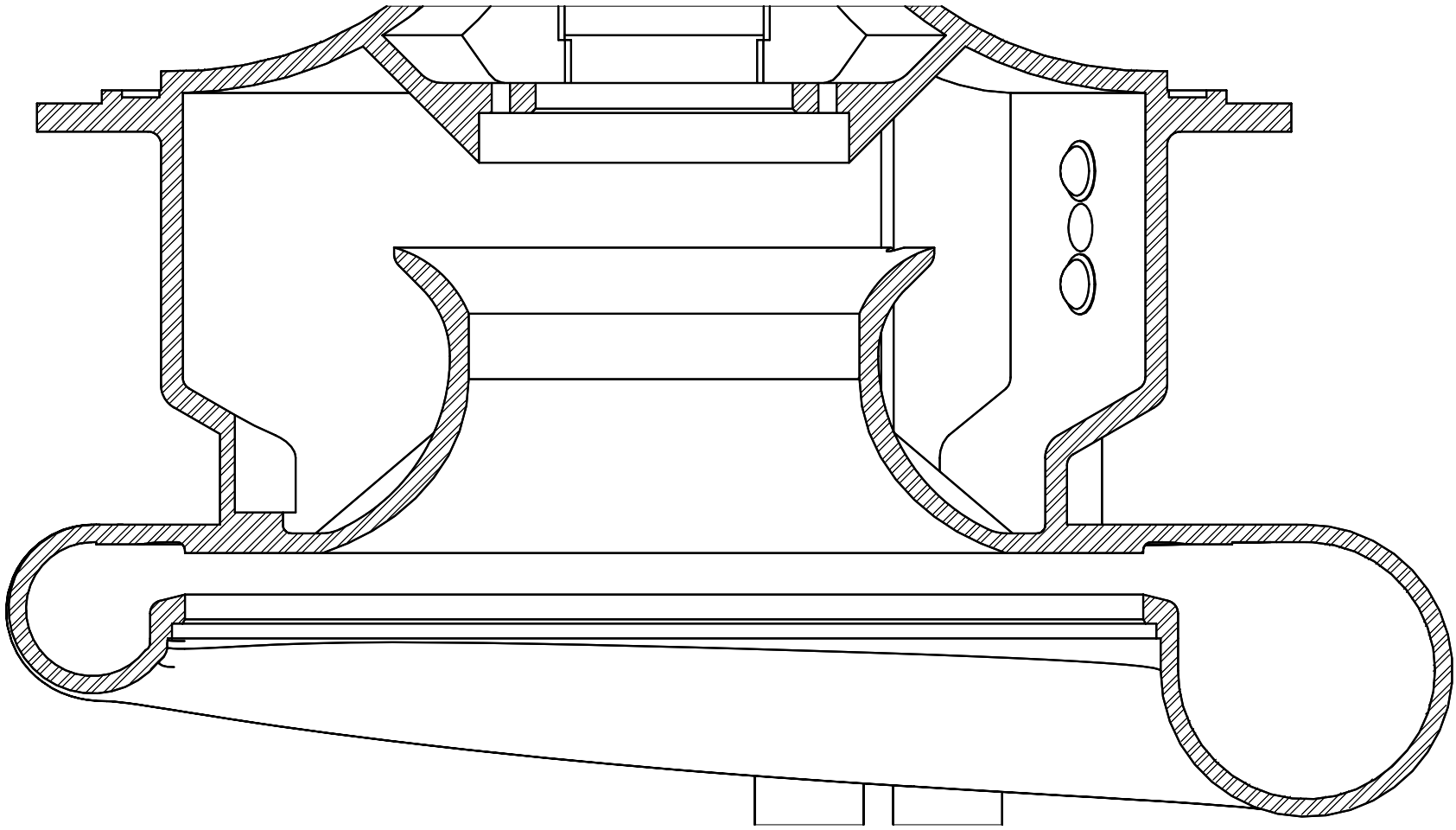

A series of horizontal lines for writing the answer.

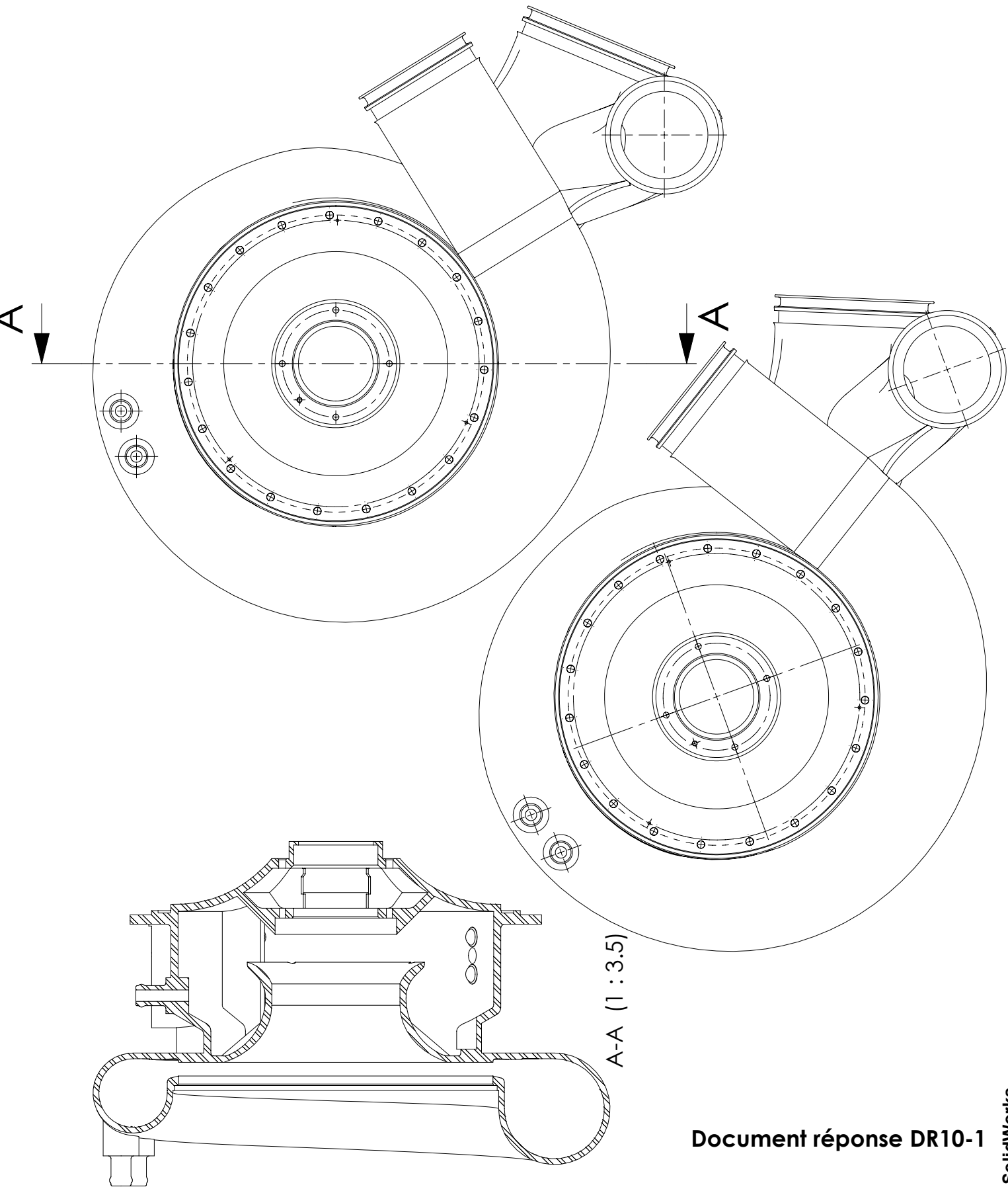

Document réponse DR10-1

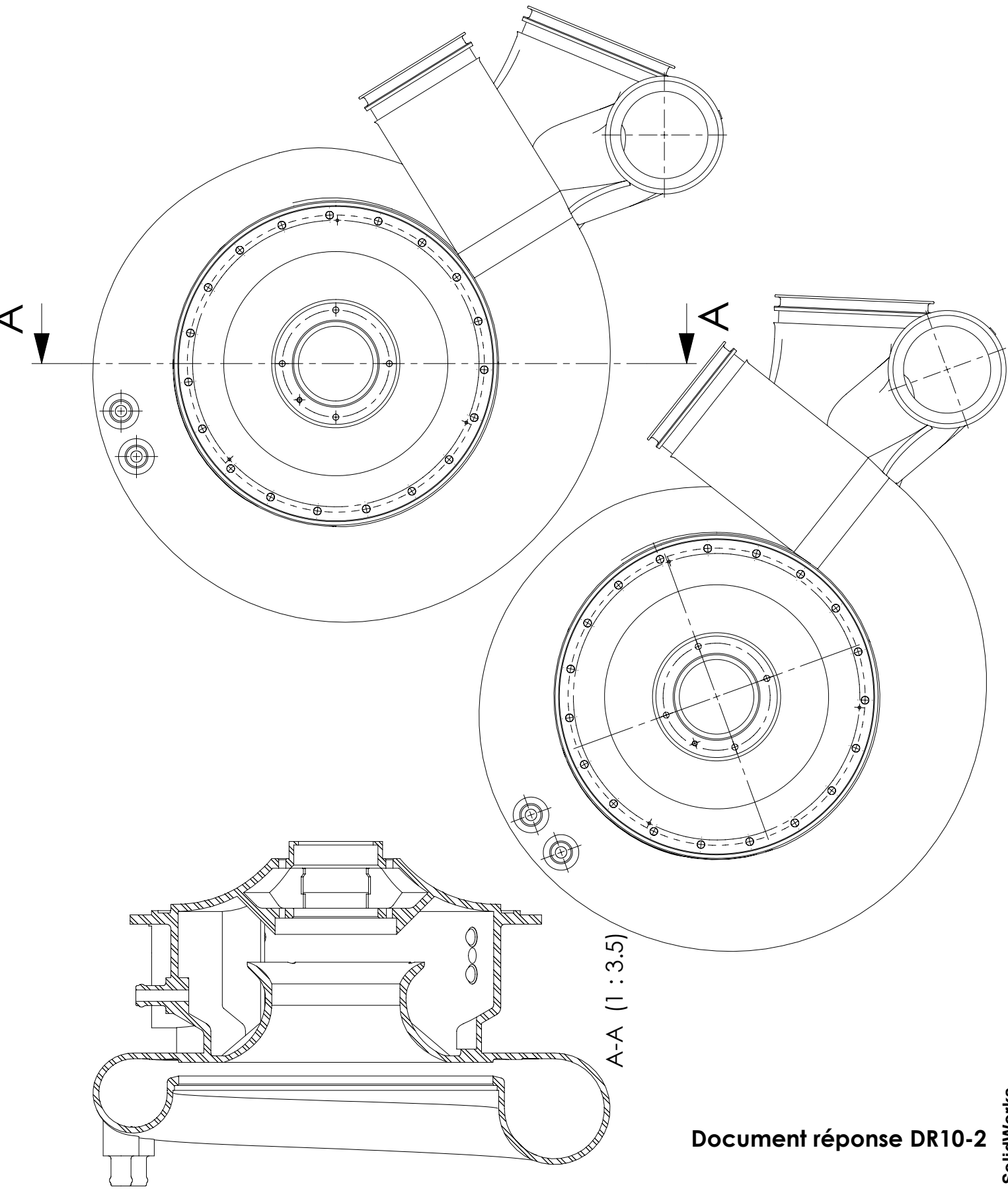

A-A (1 : 3.5)

Document réponse DR10-2

